



BUILDING VALUE SINCE 1906

EclipseDryer[®] B-740, B-748

Dryer Troubleshooting and Information Guide

Effective 6/1/19

All Bobrick dryers require cleaning every 6 months to ensure that they function effectively. Please note that failing to clean the dryer may result in malfunction and can void the warranty.

(Refer to page 6 of the [Dryer Troubleshooting and Information Guide](#) for Routine Maintenance Instructions)

www.bobrick.com

BOBRICK DOMESTIC

Email: customerservice@bobrick.com

Corporate Office - Los Angeles - Bobrick Washroom Equipment

6901 Tujunga Avenue, North Hollywood, California 91605-6213

Customer Service: 818.982.9600, Fax: 818.503.9287

New York - Bobrick Washroom Equipment, Inc.

200 Commerce Drive, Clifton Park, New York 12065-1350

Customer Service: 518.877.7444, Fax: 518.877.5029

Canada - Bobrick Washroom Equipment Company

45 Rolark Drive, Scarborough, Ontario M1R 3B1

Customer Service: Eastern Canada: 877.423.6555, Fax: 423.765.8555

Western Canada: 877.423.6444, Fax: 423.503.8444

BOBRICK INTERNATIONAL

Email: international@bobrick.com

Corporate Office - Bobrick Washroom Equipment, Inc.

6901 Tujunga Avenue,, North Hollywood, California 91605-6213 USA

Customer Service: +1 818.764.1000, Fax: +1 818.503.9941;

United Kingdom Bobrick Washroom Equipment Limited

Phone: +44 (0)20.8366.1771, Fax: +44 (0)20 8363 5794; Email: info@borick.co.uk

Germany Phone: 0800.79.00.456; Email: info@bobrick.de

Australia Bobrick Washroom Equipment Pty. Ltd.

Phone: +1800 353158, Fax: +1800 221926; Email: info@bobrick.com.au

TrimDry™ B-7120, B-7128 ADA Hand Dryer

Contents

	Page
Instructions for Using the Dryer Guide	2
Sample Dryer Service Information Sheet	3
Date Code Information	4
Routine Maintenance Instructions	5
Information and Troubleshooting	6
Schematic Diagram	7
Limited Warranty	8

Instructions For Using The Dryer Guide

- Signs for your safety:



General mandatory sign (to be accompanied where necessary by another sign)



Danger: Electricity

- Please fill out the Dryer Service Information Sheet completely. If a section is not necessary/available insert N/A in the space.
- If the faulty dryer has been installed for 2 months or less, then **replace complete dryer and return faulty unit to the nearest [Bobrick Customer Service Department](#)**.
- When you receive a call concerning a dryer problem inform, the customer/end user to **clean the dryer and check the motor brushes** before going on with diagnosing the problem. Fax them the cleaning instructions from the guide. If the dryer still does not function after cleaning, then continue filling out the Dryer Service Information Sheet.
- Inform the customer/end user that the malfunctioning/replaced parts must be returned to the Bobrick Customer Service Department or a charge will be made for replacement parts.



Dryer Service Information Sheet

Distributor/Rep/End-User Name: Bobrick's best

Address: 12345 Your Street, Suite 100

City: Toon Town State: Your State Zip code: 98765

Job Name: Fantasy Lane Job Location: My Town

Contact Name: Jessica Rabbit Telephone: (555) 555-3333 Fax: (555) 555-4444

Email: jrabbit@bobricksbest.com Account #: 99999 Sales order #: 246810

Invoice #: 35791 Invoice Date: 03/03/20

Dryer Model Information:

Automatic Dryer: TouchButton Dryer: (check one)

Dryer: Dryer: (check one)

Dryer model #/voltage: 740 115V

Quantity defective: 1 Quantity on job: 2 Date of installation: 06/03/20

Date code (as seen on bottom edge of cover on dryer UL label. For example: 04A): _____

Dryer Information:

When did dryer problems first occur from date of installation?

(Circle one) Upon Installation 0-2 Months 2+ Months Out of Warranty

If dryer problem occurred within two months of installation, REPLACE dryer and return faulty dryer.

Does the dryer in any way function now? No (Yes or No)

Has the dryer been cleaned in the past 6 months? No (Yes or No). If No, send a cleaning sheet and await outcome.

Full description of fault: Unit would not start upon installation.

Reference to Diagnostic Sheets:

Problem and possible solution: Faulty controller

Problem number(s) (as seen in left margin on diagnostic sheet): # 1 F

Repair kit/parts required (if dryer needs to be returned write RETURN): Return

Part number(s) for replacements: Complete Unit Replaced on SO #: _____

ANY DEFECTIVE PARTS MUST ACCOMPANY THIS COMPLETED SHEET TO BOBRICK'S SERVICE DEPARTMENT.

Information sheet completed by: Your Name Completion Date: 6/6/20

Branch/Rep Firm: _____

Date Code Information

The date code on all Bobrick Dryers is found on the upper left corner of the rating label and on the serial number label.

The date code will contain two digits and one letter.

The digits designate the week and the letter designates the year.

Example: 30Z week thirty, year 2000.

All digits and letters are in ascending order.

Weeks are numbered from 1 to 52 for each year.

V = 2019

U = 2018

T = 2017

S = 2016

R = 2015

P = 2014

N = 2013

M = 2012

L = 2011

K = 2010

J = 2009

H = 2008

G = 2007

F = 2006

E = 2005

D = 2004

C = 2003

B = 2002

A = 2001

Z = 2000

Y = 1999

X = 1998

W = 1997

V = 1996

U = 1995

T = 1994

S = 1993

R = 1992

P = 1991

N = 1990

M = 1989

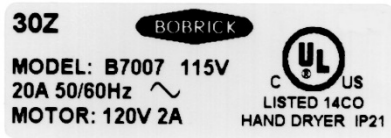

Rating Label

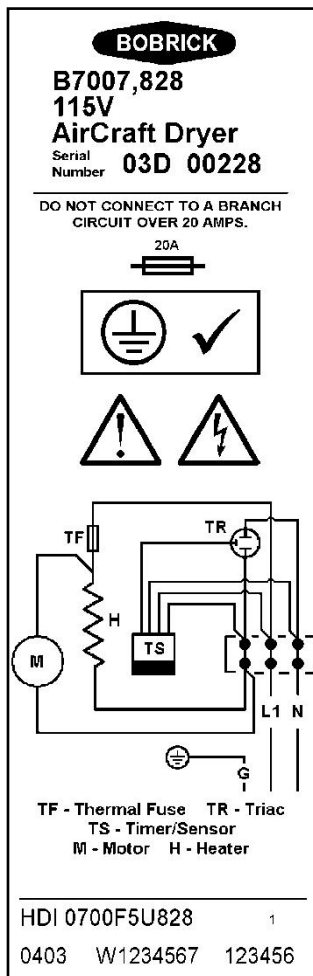

← Date code and serial number

Serial Number Label

Routine Maintenance Instructions

- All Bobrick Dryers require cleaning every 6 months to ensure that they function effectively. Please note that failing to clean the dryer may result in malfunction and can void the warranty.
- If the dryer is installed in an area prone to dust and dirt this cleaning procedure should be carried out more frequently.
- Check the length of motor brushes, where applicable, when performing the cleaning procedure.

Cleaning Instructions:



Warning
Risk of electric
shock



Disconnect power
supply before
removing cover

a) The Exterior of Cover

Should be cleaned with a damp cloth, **DO NOT** use aggressive cleaners or solvents as they may permanently damage the surface.

Bobrick dryers are drip proof (IP21 or better, see rating label). **DO NOT** spray with liquids to an extent that they could enter the unit.

b) The Interior

Having turned off all power to the dryer, remove the cover.

Using a small brush or vacuum, carefully clean out the build up of dust and lint.

Check the length of the motor brushes. If less than ½" replace. Check that motor brushes are installed correctly and that brushes are worn evenly.

Replace the cover.

Turn the power back on.

Information and Troubleshooting for the EclipseDryer® B-740, B-748

For complete set of Installation Instructions refer to form No. 740 748-69

Information about the Dryer:

- Durable, deep drawn steel cover with choice of white vitreous enamel or bright polished chrome plated finish.

Product Type:

B-740 Vitreous Enamel Cover (pictured).

B-748 Chrome Plated Cover.



Electrical Characteristics:

Models B-740 (Vitreous enamel cover), B-748 (Chrome-plated cover), 115V AC, 20 Amp, 2300 Watts, 50/60Hz, Single Phase; cULus Listed.

Models B-740 (Vitreous enamel cover), B-748 (Chrome-plated cover), 208–240V AC, 9–10 Amp, 1900–2400 Watts, 50/60Hz, Single Phase; VDE Approved, CE marked, cULus Listed, and CCC approved.

Removal of Cover

Start installation of dryer by removing cover. Loosen single cover-locking screw located in recess in the air inlet/outlet grille using a Phillips-head screwdriver.

To remove cover, place a hand on each side of the cover and tip the bottom away slightly from the air inlet/outlet grille. Lift the cover upwards to release the top retaining bracket from the mounting base.

If a fault occurs with the dryer:

1. Check that the electrical supply is OK.
2. Check that the circuit breaker is switched on.
3. Check that sensor is not obstructed, the sensor optics can be cleaned with a cotton swab.

Replacement Parts

740-120Grille

740-25 Backplate

740-150Dryer Cover (White)

748-150Dryer Cover (Chrome)



Warning
Risk of electric
shock



Disconnect power
supply before
removing cover

Schematic Diagram 115V Dryer

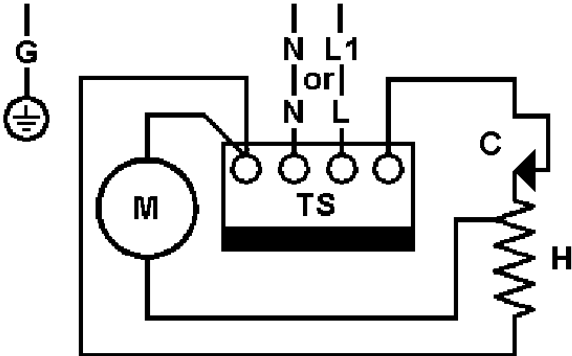

C - Cutout
TS - Timer/Sensor
M - Motor H - Heater

Schematic Diagram 208-240V Dryer

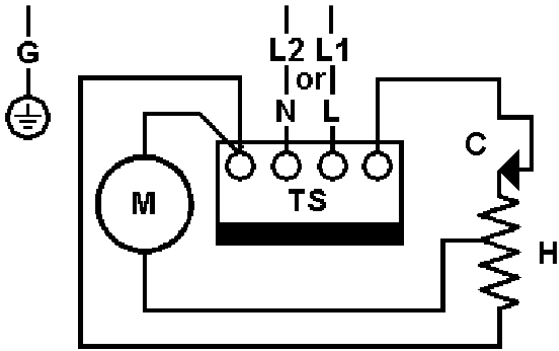

C - Cutout
TS - Timer/Sensor
M - Motor H - Heater

Limited Warranty

The Bobrick B-740 & B-748 EclipseDryer® and all parts (except motor brushes) are warranted to the original owner of the installed unit for ten years from date of original installation, against defects in factory workmanship or material under normal use and service*.

Motor brushes shall be warranted for three years from date of installation.

This warranty is limited to repair or exchange of defective parts at the option of Bobrick Washroom Equipment, Inc.

THIS WARRANTY DOES NOT COVER ACCIDENTAL DAMAGE, IMPROPER HANDLING OR INSTALLATION, OR REPAIRS MADE BY UNAUTHORIZED PERSONS, AND SPECIFICALLY EXCLUDES CLAIMS FOR INDIRECT, ACCIDENTAL OR CONSEQUENTIAL DAMAGES TO PROPERTY. THE IMPLIED WARRANTIES OF MERCHANTABILITY AND FITNESS FOR A PARTICULAR PURPOSE ARE LIMITED TO THE SAME DURATION OF THE ABOVE WARRANTY.

Some states do not allow the exclusion of incidental or consequential damages, so the above limitation or exclusion may not apply to you. Some states do not allow limitations on how long an implied warranty lasts, so the above limitation may not apply to you. This warranty gives you specific legal rights, and you may also have other rights which vary from state to state.

*** Normal service constitutes performing the following preventive maintenance procedures at six-month intervals:**

Remove cover and clean any lint, dust or grease from air inlet/outlet grille.

Visually inspect motor brushes to ensure remaining brush length is a minimum of 1/2-inch (13mm).

Labor costs for preventive maintenance shall be at owner's expense.

For repair or exchange of defective part, send the part together with installation date and serial number to Bobrick.